

W2000 Series



Smart VOC Monitoring & Control System For Continuous Volatile Organic Compounds Detection



W2000 Series VOC Monitoring & Control System is environmentally sealed, with an integrated revolutionary fixed VOC detector that gives you reliability, accuracy and results you can trust.

Features:

- Rapid, accurate detection of VOCs and eliminates false readings found with other competing PID technology
- Typhoon Technology stops condensation forming within the PID
- Selectable range (0.001–10ppm, 0.01–50ppm, 0.1–1000ppm or 1–3000ppm)
- Seamless integration of IIoT Solutions between Node-RED and the intelligent gateway, IOT telemetry, gives an ideal platform for collecting, processing and transferring of data suitable for use at industrial environment
- Industrial peristaltic pump with low shear, gentle handling without impellers, vanes, lobes or valves in the fluid path
- Sample preconditioning air filtration system with optimum performance
- Environmentally sealed to IP65
- Simple installation and servicing



Protecting People, Assets and The Environment



INDUSTRIAL
INTERNET
OF THINGS

TECHNICAL SPECIFICATION	
SENSOR (PID)	10.6 eV lamp with Ion Science's Fence Electrode, anti-contamination and Typhoon technology
INGRESS PROTECTION RATING	IP65
POWER	110/230 Vac
RANGE	0.001-10 ppm, 0.01-50 ppm, 0.1-1000 ppm and 1-3000ppm
RESPONSE	Detection time T90 less than 10 secs
ACCURACY	+/- 5 % at calibration point
MEASURING INTERVAL	1 second
OPERATING HUMIDITY:	0 – 100 RH% (condensing)
OPERATING TEMPERATURE:	-20°C to + 50°C

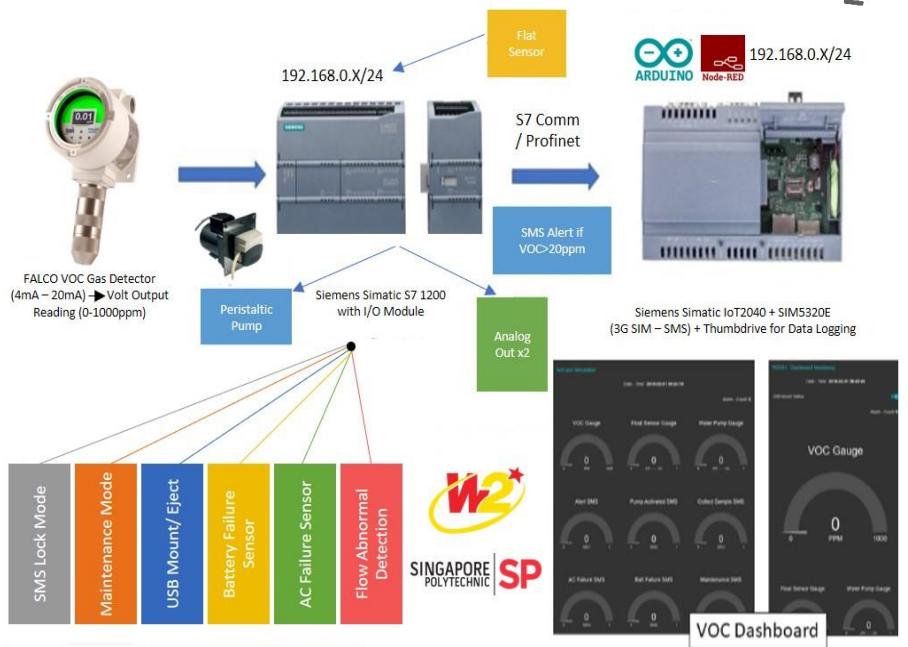

Applications include:

- Manufacturing
- Processing
- Waste water treatment
- Pulp & paper
- Pharmaceutical
- Indoor / Outdoor air quality
- Solvent recovery systems
- Industrial painting & coating

W2 Industrial Service Hub introduces W2000 series SMART VOC Monitoring & Control System, to detect and monitor last inspection chamber (IC) of trade premises before the discharge of industrial used water, or trade effluent into the public sewer and send alert if there was an illegal discharge. Discharge containing a high concentration of VOCs can cause fires in the sewer pipeline and downstream water reclamation plants (WRPs) in Singapore.

W2000 Series VOC Monitoring & Control System is a fixed, continuous area monitor designed for installation in a safe, non-hazardous environment. The integrated fixed VOC detector has the ability to detect a wide range of volatile organic compounds (VOCs) using patented photoionisation detection (PID) technology.

With accuracy in monitoring the gas reading from the detector, it compliment well with the industrial IOT telemetry where it is reliable for collecting, processing and transferring data in the system. This include sending out a SMS alert when high value of VOC is detected. W2000 Series gives you a total integrated solution ideal for applications where a sample needs to be drawn remotely.

Ordering Requirements

The following code is designed to help in selection of the correct unit. Please contact sales directly if other options is required.

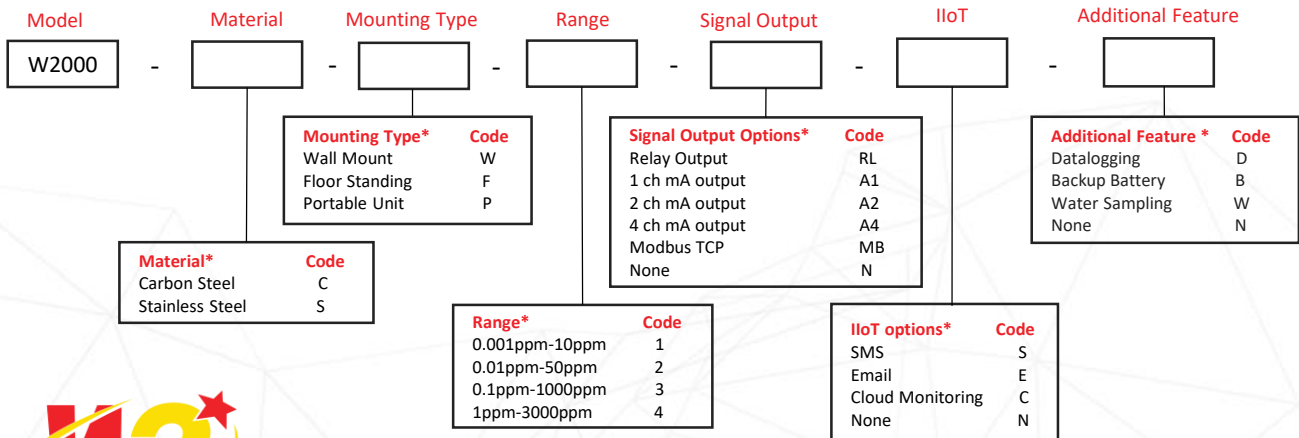

© 2018 W2ISH 10/18

Remarks: While every effort has been made to ensure accuracy in this publication, no responsibility can be accepted for errors or omissions. Data may change and this publication is not intended to form the basis of a contract.